

P1-1727 <図面・規格表>
図面・規格表の訂正

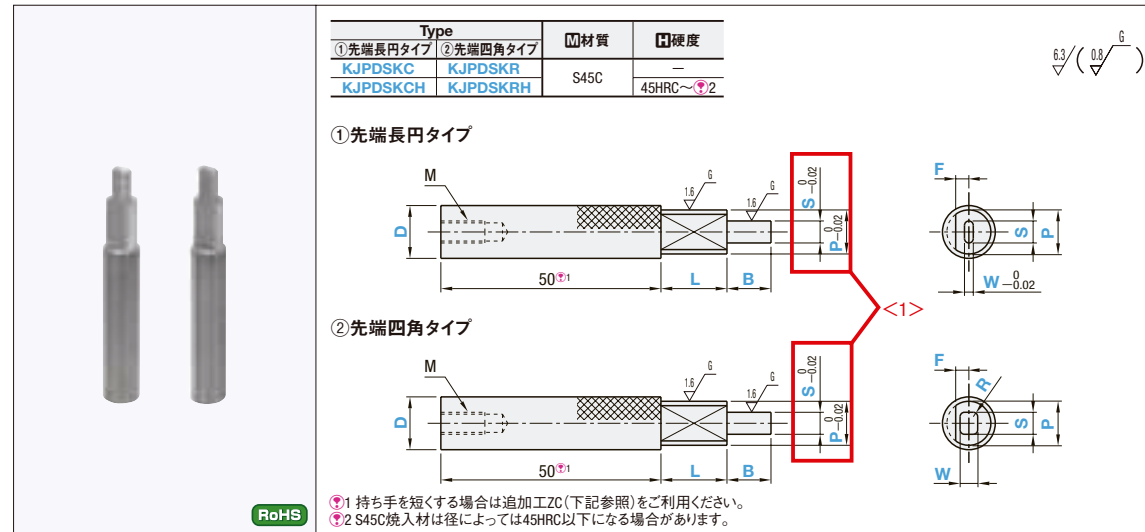

■先端長円タイプ

型式 Type	D	指定0.01mm単位			指定0.1mm単位	指定1mm単位		M	¥基準単価	
		P	W	S (P>S)	F (F<P/2) F>W/2	L	B		KJPDSKC	KJPDSKCH
KJPDSKC KJPDSKCH	8	4.10~6.50	W<S<P (W \geq 3.00)	4.00~6.40	1.6~3.1	5~20	5~20	M4	6,000	6,700
	10	4.10~8.00		4.00~7.90	1.6~3.9				6,000	6,700
	12	4.10~10.00		4.00~9.90	1.6~4.9				6,300	6,900
	16	6.10~14.00		6.00~13.90	1.6~6.9				7,900	8,800
	20	10.10~18.00		10.00~17.90	1.6~8.9				8,200	9,500
25	14.10~23.00	12.00~22.50	1.6~11.4	10,500	11,000					

■先端四角タイプ

型式 Type	D	指定0.01mm単位			指定0.1mm単位	指定1mm単位		M	¥基準単価		
		P	W	R	S (P>S)	F (F<P/2) F>W/2	L		B	KJPDSKR	KJPDSKRH
KJPDSKR KJPDSKRH	8	4.10~6.50	W<S<P (W \geq 3.00)	0.2 \leq R<W/2	4.00~6.40	1.6~3.1	5~20	5~20	M4	6,000	6,700
	10	4.10~8.00			4.00~7.90	1.6~3.9				6,000	6,700
	12	4.10~10.00			4.00~9.90	1.6~4.9				6,300	6,900
	16	6.10~14.00			6.00~13.90	1.6~6.9				7,900	8,800
	20	10.10~18.00			10.00~17.90	1.6~8.9				8,200	9,500
25	14.10~23.00	14.00~22.50	1.6~11.4	10,500	11,000						

<訂正用>

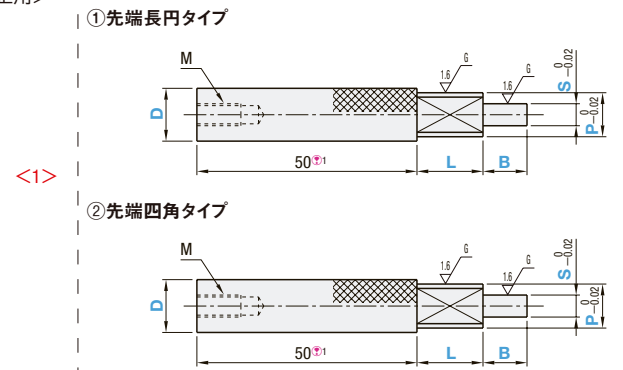

<2> F (F<P/2) F>W/2

<3> F (F<P/2) F>W/2